

Assembly View
(shown unbent for ref. only)

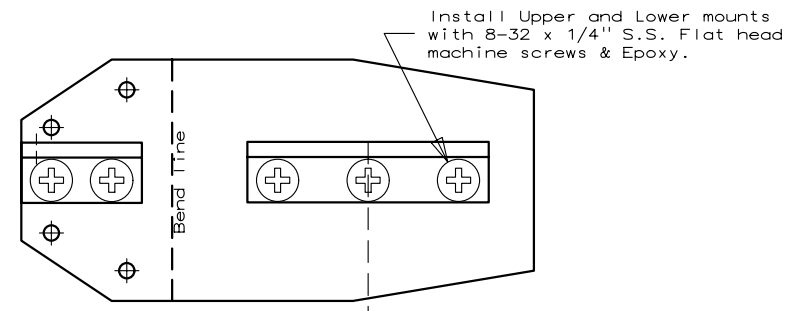

Upper Mount
(1 req'd as shown;
1 req'd mirror image)

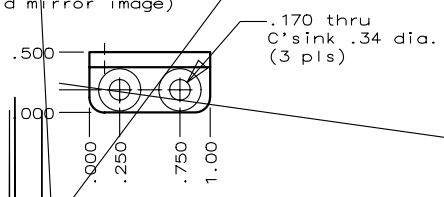

Lower Mount
(2 req'd as shown)

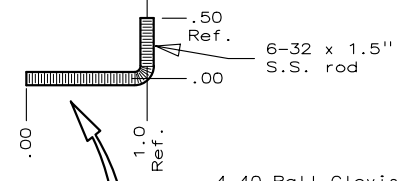
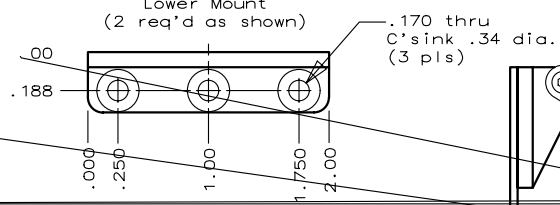

4-40 Ball Clevis
Secure with 4-40 S.H.C.S. & Loctite

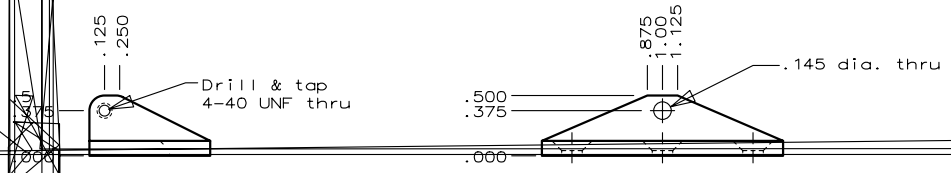
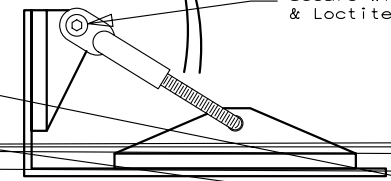

Center this screw on center line of rail

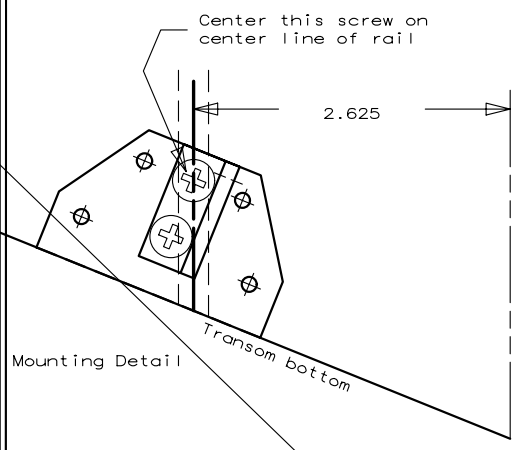

Trim Tab
Design by Brad Mahs
Copyright 1996